

Product Name	Commercial Single Hob Induction Table Wok Tops	Quantity		Item#	
					
<p>Standard Features</p> <ul style="list-style-type: none"> • Over 90% energy efficiency rate . • Simple control: use the power control knob to switch on/off, • Turn the power control knob to make step-less power regulation • The LED indicator will show the power level and also in case of error, it will show the error code enabling user to diagnose and correct minor problems • Integral grease filter to ensure clean air intake • Internal cooling fan to keep internal electronics cool • Automatic pan detection provides instant energy transmission to pan and automatic switch off when pan is not present. • Automatic power adjustment when ambient temperature rises too high or in case of empty pan heating to prevent overheating • Easy to clean high-impact glass-ceramic top surface • Pan characterization feature measures pan almost instantly to allow unit to supply optimal power to each pan at every setting • Compact design for easy portable plug and play around the kitchen • Germany TUV-Rheinland CE approved 					
<p>Middleby Food Service Equipment (Qingdao) Co., Ltd. No.1 Jinxuan Road, High tech Zone, Qingdao 266100, Shandong,P. R. China.</p>				<p>Phone:+86532-8667-2001 Fax : +86532-8667-2003</p>	

This Document Contains Confidential information, the Dissemination, Publication, Copying or Duplication of this Document or any hardware, software, or ideas described herein without Prior Written Authorization is Strictly Prohibited.
© 2023 Middleby Food Service Equipment (Qingdao) Co., Ltd.

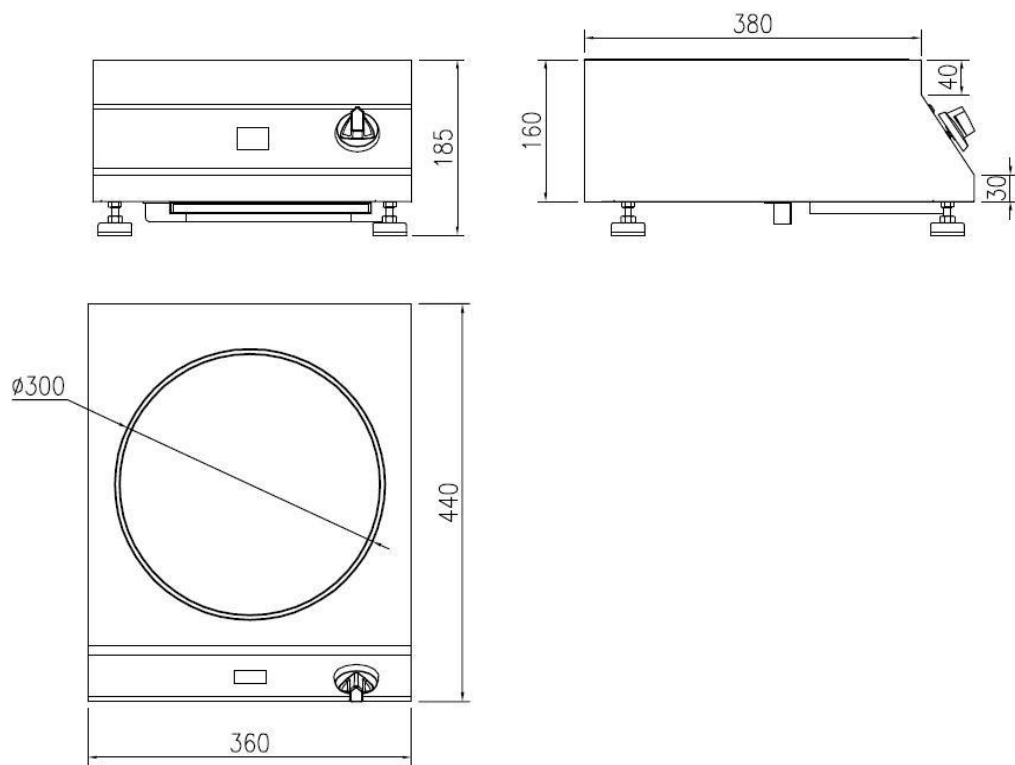

Specifications

Model Number	IND-13W-3500	IND-13WH-5000
Power Requirements	230V AC, 50/60Hz	3N~400V AC, 50/60Hz
Power Consumption	3,500W(MAX)	5,000W(MAX)
BTU Comparison	31,000BTU	44,000BTU
Amperage	16A(MAX)	7.5A(MAX)
Ceran Glass	Ø300 SCHOTT Ceran Glass	Ø300 SCHOTT Ceran Glass
Housing Material	SUS304, T=1.5mm	SUS304, T=1.5mm
Dimensions(mm)	360*440*185	360*440*185
Weight(kg)	13(With Wok)	16(With Wok)
Packaged Dimensions(mm)	590*470*380	590*470*380
Packaged Weight(kg)	16(With Wok)	18(With Wok)
Power Cord Length(mm)	1900	1900
Plug Type	EU plug	Not Included
Warranty	1 year	1 year

Middleby Food Service Equipment (Qingdao) Co., Ltd.
No.1 Jinxuan Road, High tech Zone, Qingdao 266100,
Shandong, P. R. China.

Phone: +86532-8667-2001
Fax : +86532-8667-2003

This Document Contains Confidential information, the Dissemination, Publication, Copying or Duplication of this Document or any hardware, software, or ideas described herein without Prior Written Authorization is Strictly Prohibited.

© 2023 Middleby Food Service Equipment (Qingdao) Co., Ltd.